

Mock Examination 1

ENGLISH
TECHNICAL

B2



CONTENTS

| | |
|---|----|
| Information for Learners | 3 |
| The Structure of the Examination | 4 |
| Written Examination Part One | 5 |
| 1. Reading Comprehension | |
| A. Specifications and Operations | 6 |
| B. Technical Texts | 11 |
| 2. Language Elements | 16 |
| Written Examination Part Two | 19 |
| 3. Listening Comprehension | |
| A. Specifications and Operating Procedures | 20 |
| B. Discussions and Lectures | 22 |
| C. Instructions and Descriptions | 24 |
| D. Taking Notes | 26 |
| 4. Writing Faxes | 27 |
| Answer Sheets | 29 |
| Oral Examination | 34 |
| Points and Grades | 35 |
| Information for Teachers | |
| Procedure for Conducting a Mock Examination | 36 |
| Examiners' Sheets for the Oral Examination | 38 |
| Marking Sheets for the Oral Examination M10 and M11 | 43 |
| Marking, Points and Grades | 44 |
| Marking Criteria Writing Faxes | 45 |
| Marking Instructions Oral Examination | 46 |
| | |
| Answer Key | 48 |
| Transcript for Listening Comprehension and Taking Notes | 49 |



Mock Examination 1

ENGLISH
TECHNICAL

B2

In order to work through the Listening Comprehension part of the examination, the CD (Order No. C09M-001C) is required.

No part of this publication may be reproduced, stored in a retrieval system, or transmitted in any form or by any means, electronic, photocopying, recording or otherwise, without prior permission of the publisher.

Published by telc GmbH, Frankfurt am Main, Germany
All rights reserved
First edition 2001
© 2007 by telc GmbH, Frankfurt am Main
Printed in Germany



Important Information:

Please read this page before starting the test.

Dear Learners,

This mock examination telc English B2 Technical has been published as additional practice material for learners interested in taking the examination.

There are three ways of approaching the mock examination:

- You can take the mock examination as if it were a real examination.
- You can use the whole or parts of the mock examination for practice purposes.
- You can get a general impression of the contents and procedures of the examination.

It is important to decide which of the alternatives you wish to choose before reading on.

If you wish to work through the mock examination as if it were a real examination, you need the help of a teacher to organise the test in the same way as a real examination is conducted. In this case, please do not read further than this page. You should not read any of the test items and you should not look at the information for teachers. Wait for the information and instructions your teacher gives you.

If you wish to use this material for practice purposes, we would recommend you to keep to the specific times for the individual parts of the test – as in a real examination – e.g. 75 minutes altogether for the first part of the written examination. In this way you will develop a feeling for the time allotted for the examination. You can practise the sub-tests in the written examination, including Listening Comprehension and Taking Notes (with the help of the CD – Order No. C09M-001C). The correct answers for the individual items can be found in this publication. The sub-test Writing can be marked by your teacher or a similarly qualified person. It is of course not possible for you to practise the oral examination by yourself but you will be able to familiarise yourself with the tasks and procedures as well as the assessment criteria.

If you simply wish to have a general overview of telc English B2 Technical, all you need to do is to read the information in this mock examination carefully.

We hope you will find the mock examination interesting and that you will pass with flying colours!

The Structure of the Examination

| Sub-test | Type of Test | Points | Time (in minutes) |
|---|---|---------|----------------------|
| Written Examination | | | |
| 1. Reading Comprehension | | | |
| A. Specifications and Operations | 6 multiple-choice items 2 true/false items | 6 4 | 15 * |
| B. Technical Texts | 15 multiple-choice items | 30 | 45 * |
| 2. Language Elements | 10 multiple-choice items | 10 | 15 * |
| 3. Listening Comprehension | | | |
| A. Specifications and Operating procedures | 10 fill-in items | 10 | 18 ** |
| B. Discussions and Lectures | 15 true/false items | 15 | 18 ** |
| C. Instructions and Descriptions | 5 multiple-choice items | 10 | 15 ** |
| D. Taking Notes | 10 fill-in items | 5 | 8 ** |
| 4. Writing Faxes | writing of 2 faxes based on 6 guiding points | 10 *** | 25 |
| Oral Examination | | | |
| 1. Social and General English | Talking about oneself | 5 **** | |
| 2. Business and Technical Situations | Reacting to 5 situations | 20 **** | |
| 3. Technical Description | Presentation of device or process | 20 **** | 15-20 |

* recommended times for each sub-test

** depending on the length of the recording

*** cf. Marking Criteria

**** cf. Marking Criteria



The first sub-tests are

- 1. Reading Comprehension**
 - A. Specifications and Operations**
 - B. Technical Texts**
- 2. Language Elements**

You are allowed a total of 75 minutes for these sub-tests. You may divide up this time as you wish between the sub-tests but it is recommended you keep to the following times for each sub-test: 15 minutes for Specifications and Operations, 45 minutes for Technical Texts and 15 minutes for Language Elements.

1A. Specifications and Operations

This sub-test consists of two parts. The first part consists of up to 2 sets of product specifications with 6 multiple-choice items testing your ability to extract particular information from the specifications. The second part consists of up to 2 sets of instructions with 2 true/false items testing your ability to understand instructions correctly. Each item has only one correct answer.

1B. Technical Texts

This sub-test consists of up to 5 technical texts with a total of 15 multiple choice items testing your understanding of the gist and the detail of the texts. Each item has only one correct answer.

2. Language Elements

This sub-test consists of 2 texts with a total of 10 multiple-choice items testing your knowledge of grammatical structures and vocabulary in a technical context. Each item has only one correct answer.

Pressure sensors

Below is some detailed information about four different pressure sensors.

First read items 1 – 3. Then read the specifications. Then choose the correct answer to each question and mark a, b or c on your answer sheet.

TYPE A

| | |
|-----------------------|-----------------------------------|
| Measuring element | Silicon |
| Housing material | Titanium |
| Pressure range | 0-60 bar max. |
| Accuracy | +/- 2.5% max. pressure |
| Maximum overpressure | 4 x rated pressure |
| Burst pressure | > 10 x rated pressure |
| Supply voltage | 10V at 5mA |
| Output | 10 – 100mV |
| Electrical connection | 1 metre integrated vertical cable |
| Operating temperature | -20°C to +80°C |
| Dimensions | diameter 21mm, length 70mm |

TYPE B

| | |
|-----------------------|--|
| Housing | Thermoplastic |
| Pressure range | 5 –15 p.s.i. (1.3 – 2 bar nominal) 0 – 30 p.s.i. (1.3 – 3 bar nominal) |
| Accuracy | Error less than 0.10% |
| Overpressure | 45 p.s.i. 60 p.s.i. |
| Burst pressure | 150 p.s.i. |
| Supply voltage | 10V dc |
| Full scale output | 100mV (15 p.s.i.) 79mV (30 p.s.i.) |
| Operating temperature | - 10°C to + 95°C |
| Dimensions | overall height (including connections) 20.7mm, width 16.3mm, depth 16.3mm |

Warning: Limited to fluids which do not corrode (polyester or silicon-based materials)

TYPE C

| | |
|---------------------|---|
| Measuring principle | Precision gauge in stainless steel disc |
| Construction | Extremely strong stainless steel |
| Temperature range | 200°C to + 250°C |
| Measured pressure | - 100 bar and 0 – 350 bar |
| Accuracy | better than +/- 0.12% combined nonlinearity, hysteresis and repeatability |
| Overpressure | twice rated maximum pressure |
| Burst pressure | 450 bar |
| Excitation voltage | 14V – 15V dc |
| Output | 5V – 10V dc |
| Dimensions | diameter 40mm, length 91mm (including pressure connection) |

TYPE D

| | |
|-------------------------|---|
| Material | glass fibre/polyester |
| Pressure range | 0 – 1.00 bar (vacuum) |
| Overpressure | 2.75 bar |
| Absolute burst pressure | 5.00 bar |
| Electrical requirements | 12V dc at 0.065A |
| Output | 0 – 100mV (zero can be adjusted 0 – 2.5V) |
| Wiring | 4 core integral cable 0.75 long |
| Operating temperature | -10°C to +40°C |
| Dimensions | depth 40.5mm, length 40.5mm, height 25mm |

1A: SPECIFICATIONS AND OPERATIONS

1. You need a sensor that measures vacuum in a filter system. The power supply is 12V. Which sensor do you choose?
 - a) TYPE A
 - b) TYPE B
 - c) TYPE C
 - d) TYPE D

2. You have to measure pressures of 1.5 to 1.8 bar with an accuracy of more than 0.2%. Which sensor do you choose?
 - a) TYPE A
 - b) TYPE B
 - c) TYPE C
 - d) TYPE D

3. Your equipment must operate in environments with extreme temperature changes and high pressures. Which sensor do you choose?
 - a) TYPE A
 - b) TYPE B
 - c) TYPE C
 - d) TYPE D

1A: SPECIFICATIONS AND OPERATIONS

Drilling Machines

Below is some detailed information about four different drilling machines.

First read items 4 – 6. Then read the specifications. Then choose the correct answer to each question and mark a, b or c on your answer sheet.

| | Model A | Model B | Model C | Model D |
|---|-----------------------------|------------------------------------|--|---|
| Maximum drill capacity in mild steel (mm) | 32 | 40 | 50 | 70 |
| cast iron (mm) | 40 | 50 | 60 | 80 |
| Maximum drilling depth (mm) | 180 | 210 | 230 | 260 |
| Column diameter (mm) | 125 | 180 | 200 | 240 |
| Distance from column to spindle (mm) | 300 | 385 | 370 | 390 |
| Maximum distance from table to spindle (mm) | 835 | 800 | 900 | 730 |
| Base dimensions (mm) | 600x380 | 535x805 | 545x855 | 600x920 |
| Table dimension (mm) | 400x420 | 510x510 | 570x570 | 660x775 |
| Motor | 220V/50Hz | 220V/50Hz | 220V/60Hz | 220V/50Hz |
| Speeds (with motor 1450 rpm) | 95/135/380/ 534/750/1500 | 61/85/123/ 269/390/ 800/1500 | 54/109/169/ 237/344/507/ 712/1100/ 1500 | 51/84/158/198/ 262/447/559/ 738/966/1260/ 1500 |
| Power feed range (mm/min) | 0-20 | 0-30 | 0-40 | 0-60 |
| Power of main motor | 1 hp | 2 hp | 4 hp | 7,5 hp |
| Power of electric oil pump motor | 0.12 hp | 0.12 hp | 0.12 hp | 0.2 hp |
| Total height of machine | 2200 mm | 2380 mm | 2470 mm | 2570 mm |
| Net weight of machine | 330 kg | 640 kg | 840 kg | 1080 kg |
| Dimensions of transport box | 930x600x | 1030x620x 2300 | 1070x670x 2480 | 1160x820x 2600 2740 |

1A: SPECIFICATIONS AND OPERATIONS

- 4.** All the workpieces you have to drill are made of cast iron. The maximum diameter to be drilled is never more than 40mm and maximum drilling depth is 195mm. You need a drilling machine which weighs as little as possible. Which drilling machine do you choose?
- a) Model A
 - b) Model B
 - c) Model C
 - d) Model D
- 5.** Power for the drilling machines is provided by electric motors. These motors rotate at
- a) 220 revolutions per minute
 - b) 1450 revolutions per minute
 - c) 1500 revolutions per minute
 - d) a different speed for each drilling machine.
- 6.** You want a heavy duty drilling machine which weighs less than a ton. The table should measure more than 550mm by 550mm. Which drilling machine do you choose?
- a) Model A
 - b) Model B
 - c) Model C
 - d) Model D

1A: SPECIFICATIONS AND OPERATIONS

Instructions

Read each text carefully and then decide whether the statements in items 7 and 8 are true or not true and mark YES or NO on the answer sheet.

Installing integrated “I” dishwashers – Fitting the (matching) door front

The door of the kitchen base unit (without the drawer facia or fittings) is normally used for the door front.

The door front is fixed to the machine door outer panel using a fixing bracket which has to be pre-mounted on the rear of the door front.

Templates are provided to position the fixing bracket and the door front accurately.

Fixing brackets are already fitted on the stainless steel door front. This front cannot be shortened.

Door fronts differ in weight and it is therefore essential that the door springs are adjusted after the door front has been fitted.

7. The door springs should be shortened or lengthened after the door has been fitted.

Installation and Maintenance of Diesel and Natural Gas Engines

The engine installation should be designed with maintenance requirements in mind. Serviceable components such as filters, fittings and connections should be readily accessible to the engine operator. Routine engine maintenance will be easier if the operator has good access to the engine. An overhead crane should be available in the engine room to assist the mechanic in removing heavy parts or even the complete engine, should this be necessary. Sufficient service space must be present on all sides of the engine to allow for the removal of even the largest engine components.

8. Standard maintenance requires the use of an overhead crane.

Read each text carefully and then choose the best answer in each set of questions and mark it on the answer sheet.

A New Heating System

Instead of the usual gas, oil or electric heating systems, workers in a new office block in Guildford, England are being kept warm by heat taken from an underground heat store. In the summer, excess heat from the building is absorbed by the store which contains 30,000m³ of rock held in a porous plastic sheet through which ground water can pass.

Heat is transferred to and from the store by a 220kW electric heat pump. According to Dr. Ian Franklin, managing director of the heat pump specialists, Geowarmth Systems, which designed the new project, the temperature of the store is not expected to drop below 6°C even in the middle of winter, allowing the temperature in the 14,700m² office to

be kept at around 21°C. In the summer, when the store is used as a heat reserve, its temperature could rise to 20°C, allowing the offices in the building to be kept warm at a comfortable maximum 24°C.

In addition to space heating, the system will also provide most of the building's hot water. An electric heater will raise the water temperature by the final 10°C to 50°C.

The £600,000 project which has attracted £75,000 from the government, is expected to save the equivalent of about 70t of coal a year, giving an annual cost saving of around £10,000 over a normal heating and air-conditioning system.

9. Workers in an office block in Guildford are being kept warm in winter by
- “geothermal heat” (heat drawn from the earth's heat).
 - heat drawn from ground water by a heat pump.
 - “summer heat” trapped in a heat store.
10. In summer, the temperature in the office blocks does not rise above
- 21°C.
 - 24°C.
 - 20°C.
11. The new heating system
- will heat water to 60°C.
 - will save £10,000.
 - will use 70 tons of coal a year.

Superplastic Aluminium Alloys

Superplastic aluminium alloys (SPA) – those which behave like plastic when heated and metal when cold – have been commercially exploited in the aerospace industry since the early 1970s. Yet it is only during the last ten years or so that they have begun to be used in the manufacturing industry in general. This has led to new applications in fields as diverse as electronics, medical equipment, architectural components, the auto industry and public transport (especially railways).

Technically, a superplastic aluminium alloy is one which exhibits high tensile ductility at low strain rates, coupled with a high elongation and low flow stress at higher temperatures. Of these characteristics, the most important one is the elongation factor. In most applications, this will be slightly less than 200%, in order to maintain an acceptable material thickness, although it is technically possible to achieve a factor of more than 1000%. It is of course this stretching capability which facilitates the compressed air forming of complex shapes from a single sheet, a capability which holds many attractions for industrial designers.

LITAL 8090-SPA, for example, is an aluminium lithium alloy specially developed for aerospace applications which offers a reduced weight (of up to 10% less than conventional aluminium alloys), together with a similar degree of increased rigidity or stiffness. For increased room temperature ductility and corrosion resistance there are alloys such as LITAL 5083-SPA.

The use of compressed air forming techniques has the further advantage of high finish quality since only one component surface comes into contact with the tool. This allows low tooling costs – the majority of the tools are machined from aluminium alloys or ferrous metals. There are now three individual forming methods in common use, the chosen technique depending on size, the kind of aluminium alloy used and the complexity of the design itself. These three methods are male forming, female forming and drape forming.

Whichever method is used, however, it is the exceptional design freedom offered by the combination of air pressure forming with a metal capable of behaving like plastic, which is the most important advantage to the manufacturing industry. It is this special combination which makes the SPA process so suited to the production of components with complex shapes. But it is only recently that other valuable manufacturing advantages have begun to be widely appreciated. An important advantage is the ability to produce complicated parts from a single sheet, minimising the need for additional manufacturing and assembly. Using SPA aluminium alloys reduces production times and costs and this frequently enables designs to be simplified and component weights to be reduced. Some components that were previously made from ten individual sheet metal details can now be produced in one single forming process.

Strength is not the only advantage offered by the alloys. Although some plastics now possess better strength to weight ratios than SPA alloys, SPA is still specified by most aerospace designers because of its better fire resistance.

Because of all the advantages of superplastic aluminium there seems little doubt that it will continue to be used more and more, at least for small to medium production volumes where some kind of sheet metal or plastic would be the standard alternative. The combination of increased design freedom, high finish quality, good mechanical properties and low tooling costs offer manufacturing possibilities not found in other materials. Also aluminium is recyclable. This is an added advantage in a world in which the environmental impact of manufacturing is becoming increasingly more important.

1B: TECHNICAL TEXTS

12. Superplastic aluminium alloys

- a) are new materials made of plastic and metal.
- b) have been used for some time in general production.
- c) are no longer used in the aerospace industry.

13. Superplastic aluminium alloys

- a) are produced using the compressed air technique.
- b) are very brittle at low strain rates.
- c) can be stretched to more than ten times their original length.

14. A component made of LITAL 8090-SPA

- a) is lighter than one made from a conventional aluminium alloy.
- b) has better corrosion resistance than one made from LITAL 5083-SPA.
- c) is less rigid than one made from other aluminium alloys.

15. The use of compressed air methods means that

- a) both sides of the component are touched.
- b) inexpensive forming tools can be used.
- c) the same method can be used for all sizes of component.

16. The SPA process

- a) is only applied to the forming of complex shapes.
- b) allows complicated shapes to be produced from one sheet.
- c) offers little advantage in the assembling process.

17. SPA components

- a) are more expensive to produce than conventional aluminium components.
- b) can be shaped from a single sheet in up to ten individual forming steps.
- c) weigh less than standard aluminium components possessing the same strength.

18. Components made of SPA

- a) are easily recyclable.
- b) are stronger and lighter than plastic components.
- c) can be easily produced on a large scale.

Fax Via Email – Any Way you Like it

Need to receive a fax but don't have or want a fax machine? XOIP (pronounced keysop), a three-year-old Dutch firm, offers Internet users a free service by which they can receive faxes through their e-mail accounts. The company gives clients a special phone number in the Netherlands, U.K. or Belgium to be used as a personal fax line. XOIP forwards any faxes received on that line to the user's e-mail address as an image file. The sender of the fax pays a normal telephone charge and XOIP gets a share of the revenue from the phone company. No special software is needed. More than 100,000 people already use the service, which also includes a free voice mail system that transmits voice messages as downloadable sound files to the client's computer.

- 19.** This new service is for those who
- a) already have a fax machine.
 - b) don't have an e-mail address.
 - c) want to get faxes without a fax machine.
- 20.** In order to receive faxes, users of the system
- a) are given a new number to use for faxes.
 - b) get a new e-mail address for faxes.
 - c) use their own telephone number for faxes.
- 21.** The costs of the service for the users
- a) amount to normal telephone charges.
 - b) are mostly for the software necessary.
 - c) too high for most people.

Lamp Holders

IVOTECHS lampholder isolates the light bulb contact as soon as a bulb is removed, preventing the chance of electrical shock from the exposed contacts. The result of a suggestion from a private inventor and bought by IVOTECHS, the lampholder is designed for standard bulb fittings and was the first major improvement for over 100 years, say IVOTECHS.

One of the main obstacles to be overcome in the development of the lampholder was the selection of a

suitable material. This needed to be stable at high temperatures to ensure that the mechanism would not stick. The final choice, PET, was tested at temperatures of up to 230°C for two years with no sign of deterioration. This is 80°C more than can be expected under normal conditions.

The lamp holder allowed IVOTECHS to enter the market for electrical fittings. Despite its extra features, however, it has always sold at a price which is competitive with other products.

22. The lamp holder

- a) can be used with ordinary light bulbs.
- b) was invented by IVOTECHS.
- c) was originally invented 100 years ago.

23. The material used for the lamp holder, PET,

- a) deteriorates at temperatures under 80°C.
- b) is guaranteed for two years.
- c) remains intact at high temperatures.

Read the following texts and decide which word or phrase a, b, c or d is missing in items 24 – 33. Mark your answers on the answer sheet.

The Battery and the Charging Circuit

In a car, electrical energy (produced by chemical action) is **24** _____ in the form of current flow to electrical components when they are connected to the battery. As the battery continues to supply current, all the available chemical energy stored is used up. In order to **25** _____ additional current, the chemical energy must be restored to the battery. The generator does this **26** _____ current to the battery in the opposite direction to the discharge. **27** _____ the battery is a chemical device, it should be noted that the generator is electro-mechanical, converting mechanical power from the engine into electrical power. When the battery is being charged by the generator, the voltage **28** _____ across the battery is called the “charging voltage”.

- 24.** a) prepared
b) presented
c) processed
d) provided
- 25.** a) reach
b) require
c) prevent
d) supply
- 26.** a) by sending
b) in order to send
c) in sending
d) sending
- 27.** a) As
b) Because
c) When
d) Whereas
- 28.** a) measured
b) measures
c) measuring
d) be measured

High Technology in Building

One measure of the efficiency of a building particularly liked _____ 29 _____ structural engineers is the way a load goes from the top to the ground. In the Bank of China building in Hong Kong _____ 30 _____ has 70 floors, the load takes the usual way downward. But the building is not of usual height and this area has very strong winds. Instead of two structural systems, one for the vertical loads and the other for the purpose _____ 31 _____ wind forces, the building only has a single system for both of these. Lightweight steel bars form a three-dimensional frame which _____ 32 _____ the vertical planes of the four faces of the building and the two diagonals. The frame transfers the loads to the vertical columns of reinforced concrete which _____ 33 _____ the loads directly to the ground.

29. a) by
b) from
c) to
d) with
30. a) what
b) which
c) who
d) whose
31. a) by resisting
b) of resisting
c) resist
d) to resist
32. a) adds
b) attaches
c) breaks
d) connects
33. a) are taking
b) take
c) have taken
d) took



3. Listening Comprehension
A. Specifications and Operating Procedures
B. Discussions and Lectures
C. Instructions and Descriptions
D. Taking Notes

The time for these sub-tests is approximately 85 minutes, depending on the length of the recording.

For this sub-test you need the CD (Order No. C09M-001C).

All the pauses are on the CD. In the real examination the CD will not be stopped.

A. Specifications and Operating Procedures

This sub-test consists of a recording describing one or more diagrams with 10 items to be completed, either by filling in a missing word or phrase or by deciding whether a statement is correct or incorrect according to what you hear on the tape. You should write the missing words or phrases or mark YES or NO on your answer sheet.

B. Discussions and Lectures

This sub-test consists of a recording of a discussion, interview or lecture with 15 statements testing your understanding of the gist and the detail. You should decide whether the written statements are correct or incorrect according to what you hear on the tape. You should mark YES or NO on your answer sheet.

C. Instructions and Descriptions

This sub-test consists of 5 short recordings of technical instructions or descriptions with one multiple choice item for each recording testing your understanding of what is being said. Each item has only one correct answer.

D. Taking Notes

This sub-test consists of 10 short recordings each containing one piece of information in answer to a question which you can read in your examination booklet. You should write the answer on the answer sheet.

In all these sub-tests you may make notes but in the real examination marks can be given only for the answers which are written on the answer sheets. Notes will be destroyed by the examination centre. Make sure you have enough time to write your answers on the answer sheets.

3A: SPECIFICATIONS AND OPERATING PROCEDURES

Two Valves Used to Control Pressure

The two diagrams, I and II, illustrate the two different types of valves used to control the flow of water.

Some parts have been labelled A - K .

First look at the general layout of the diagrams and read the test items.

Then listen to the speaker.

You will hear the text in two parts.

You may take notes if you wish.

After each part, you will have time to study the diagrams again and read the test items. Decide whether the sentences are correct -YES- or incorrect -NO- and add the missing words.

You will then hear the complete text a second time.

When you have heard the complete text a second time, check your answers and transfer your answers to the answer sheet.

Please note: Minor spelling mistakes will not affect the result.

Before the speaker starts you have 90 seconds to study the diagrams.

- 34.** Part A is referred to as _____ .
- 35.** Part D is referred to as the pressure chamber.
- 36.** Part B is mentioned.
- 37.** Part C is made of _____ .
- 38.** This type of valve can be easily adjusted.
- 39.** The more the water level in the tank rises, the more the float falls.
- 40.** Parts F are referred to as _____ .
- 41.** Part G is mentioned.
- 42.** Parts H are referred to as _____ .
- 43.** Part K has a safety function.

3A: SPECIFICATIONS AND OPERATING PROCEDURES

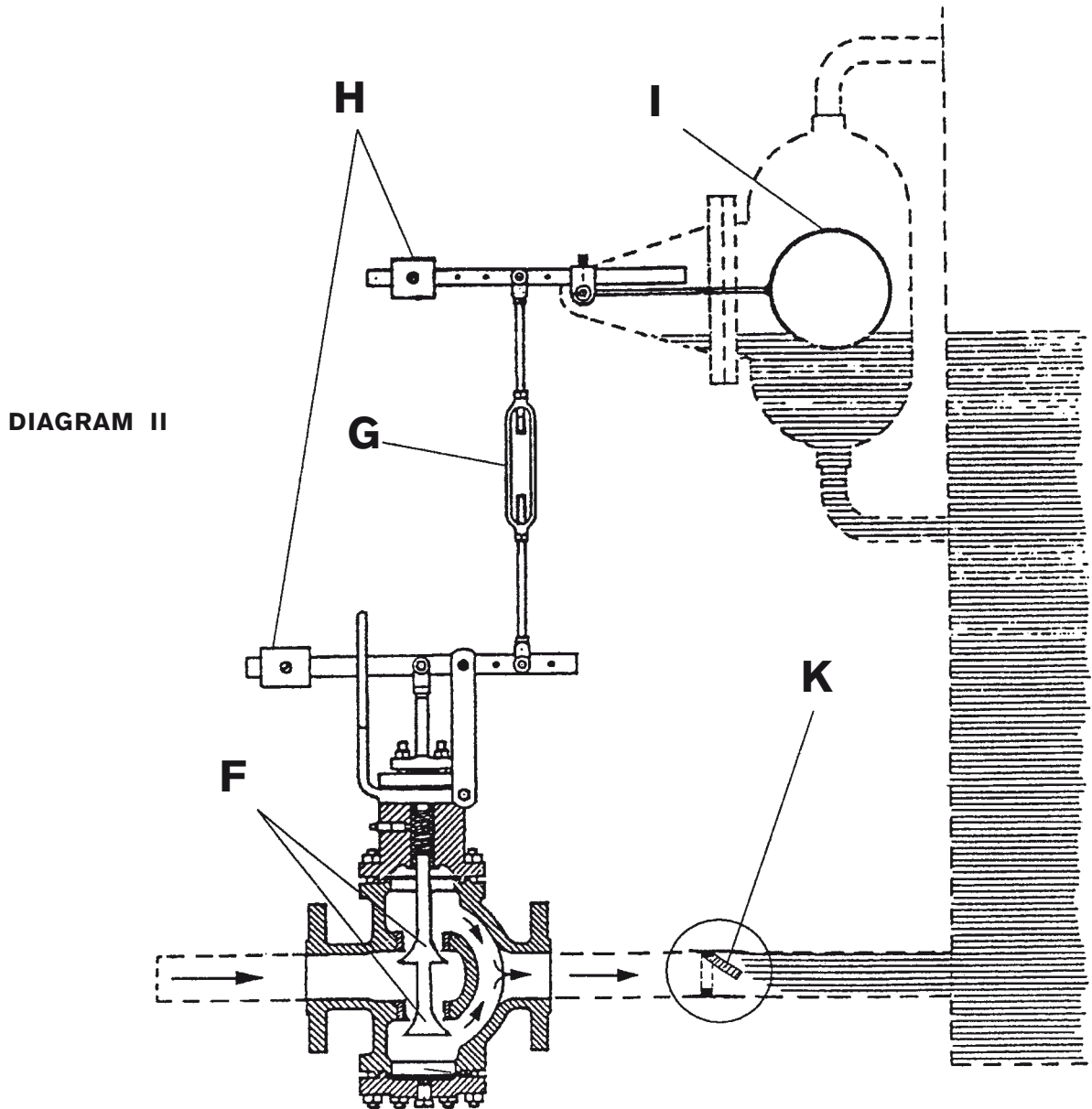
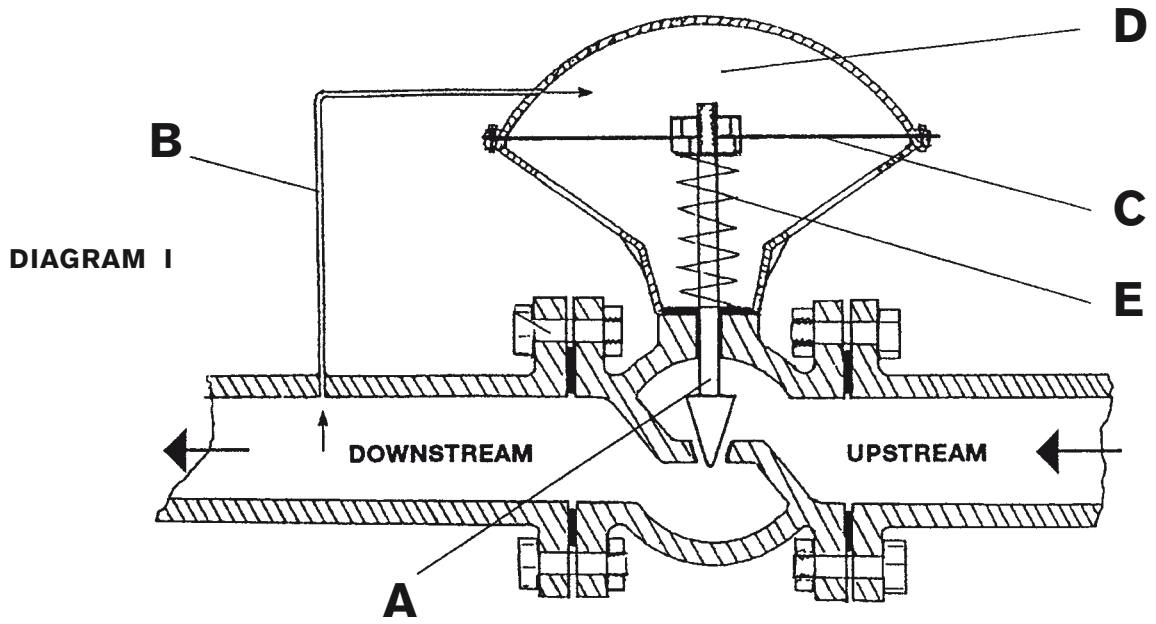

3B: DISCUSSIONS AND LECTURES

Danger – Risky Kinobis

You will now hear an interview from a radio programme .

Recent tests have shown that some cars are dangerous to drive. You are going to hear an interview with a representative of the Car-Owners' Association, talking about tests done and the results found. She will be talking about one type of car in particular – the Kinobi BK.

First read the test items 44-53 on the examination paper. You will have 2 minutes for this.

Then listen to the interview.

After that you will hear the interview again, this time in two sections.

After each section you will have time to mark whether the sentences are true - YES - or not true - NO - on your answer sheet.

You now have two minutes to read the test items.

- 44.** American and British car-owners' associations co-operated closely in testing Kinobi BKs.
- 45.** Kinobi BKs slide too easily when going around corners.
- 46.** The British test driver could not complete the test.
- 47.** The same test has been done on many other cars.
- 48.** Careful driving can prevent the car rolling over.

- 49.** Two people have already been killed due to Kinobi BKs rolling over.
- 50.** In the US 95 people have been hurt in Kinobis which have rolled over.
- 51.** Kinobi has warned all owners of this danger.
- 52.** Accidents have also happened in Kinobis when making a sudden stop.
- 53.** The Car-Owners' Association will send details to interested drivers.

3B: DISCUSSIONS AND LECTURES

Cooling Down process heat

You will now hear a speaker describing ways of cooling down process heat in power stations. First look at the diagram and read the sentences 54 - 58.

You will have 90 seconds for this.

Then listen to the speaker.

After that you will hear the speaker again.

Then mark whether the sentences are true - YES - or not true - NO - on the answer sheet.

You now have 90 seconds to study the diagrams.

- 54. All thermal power stations produce waste heat.
- 55. The once-through cooling system shown in Figure A is equipped with a heat exchanger.
- 56. Pump Y in Figure B pumps only small amounts of water to the cooling tower.
- 57. Figure B shows a cooling system in which the rising air can be used to drive fans to produce electricity.
- 58. Natural draft design cooling towers are sometimes more problematic for the environment than electrically powered fan driven ones.

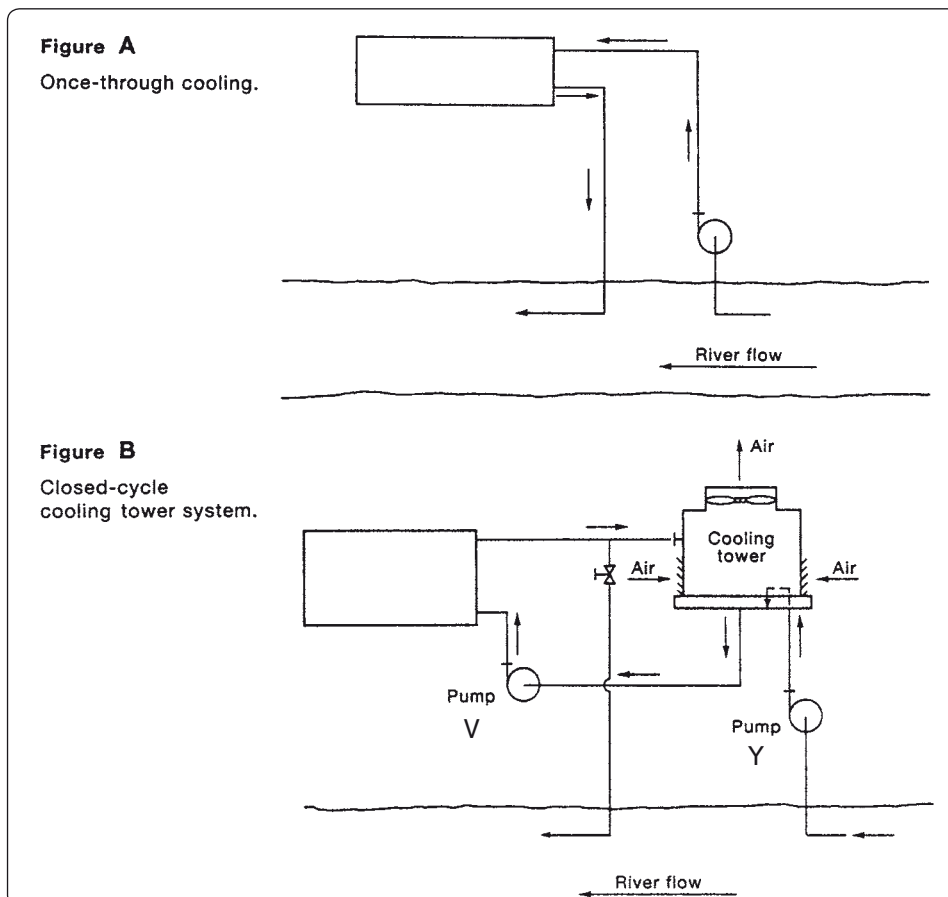

3C: INSTRUCTIONS AND DESCRIPTIONS

You will now hear five short texts. Before you listen to each individual text first read the test items and look at the diagrams (if provided). You will have 60 seconds for this.

Then listen to the text.

Then read the sentences again.

Now listen again and decide which test item is correct according to the information given.

Mark your answer - a, b, or c - on the answer sheet.

You now have 60 seconds to read the test items.

59. New Developments in the Car Industry

The new ABB development

- a) can be quickly recharged at special charging stations.
- b) does not produce gaseous emissions.
- c) weighs four times more than normal batteries.

60. Shop-Floor Safety Instruction

When you work at a lathe

- a) clean the machine with compressed air after you have finished your work.
- b) don't work in oily clothes.
- c) keep the cutting fluid in a metal container.

61. Solar Heating

Diagram A shows

- a) a one-axis concentrator.
- b) a system that requires two pumps.
- c) a system that works constantly.

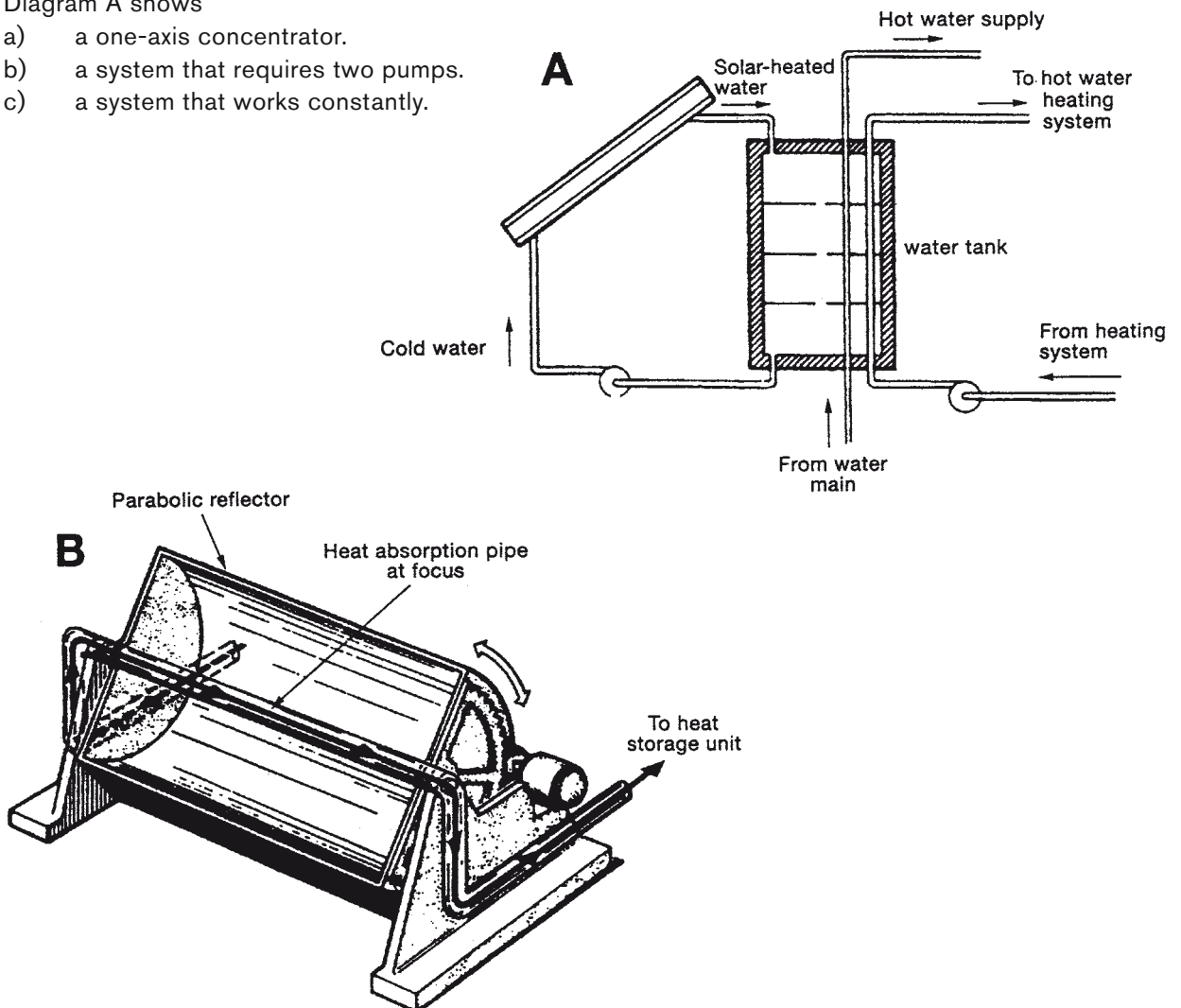

3C: INSTRUCTIONS AND DESCRIPTIONS

62. High Tension Cables for Car Ignition Systems

In the new high tension cables

- a) a lower resistance copper core is used.
- b) insulating material is no longer necessary.
- c) resistance against environmental effects has been increased.

63. Comparing Energy Costs

Column A represents the end price for

- a) electric power.
- b) hydrogen energy.
- c) natural gas.

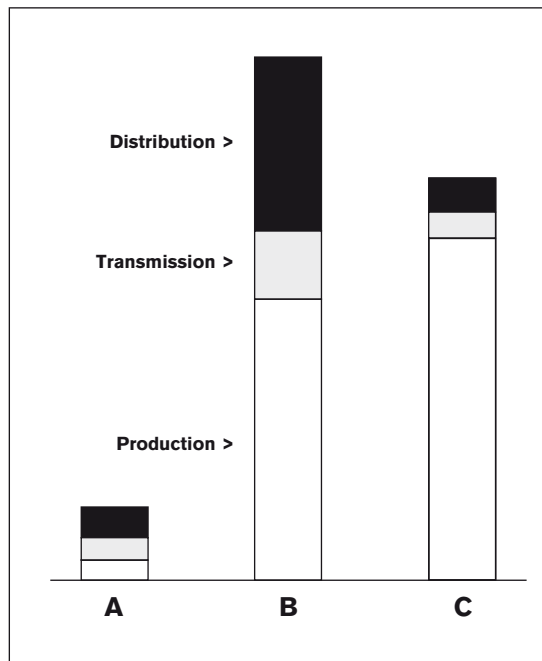

3D: TAKING NOTES

In this section you will hear ten short recordings. Listen to each recording and then make a note of the information given on the answer sheet as in the example below.

Please note: You will hear the recording only once.

Example :

Question: "What is the power range of your motors?"

"We can supply motors from 1.25 to 9.8 horsepower"

Answer:

1.25 hp – 9.8 hp or

1.25 to 9.8 horsepower or

1.25 to 9.8

- 64.** What is your name, please?
- 65.** How many employees do you have exactly?
- 66.** When can you deliver the goods?
- 67.** What size is the paper?
- 68.** What is the initial cost of each lens?
- 69.** Can you give me your fax number?
- 70.** What size are they?
- 71.** What is the weight of the consignment?
- 72.** How much is the VAT on that order?
- 73.** Can you tell me the invoice number?



The last sub-test is

4. Writing Faxes

The time for this sub-test is 25 minutes.

In this sub-test you have to write two faxes, each based on three guiding points. You are given a context consisting of a situation or a fax which you or your company have received and to which you write in reply. You may make notes or write a draft but in the real examination marks can be given only for faxes which are written on the answer sheets. Notes will be destroyed by the examination centre. Make sure you have enough time to write your faxes on the answer sheets

This is the last sub-test in the written examination.

Fax 1

You work for a company which produces and sells video equipment for conferences. You have received the following enquiry.



Write a fax in reply. Include the following points.

- 74.** Thanks for inquiry
- 75.** Sending brochure
- 76.** Representative will contact her

Fax 2

You ordered a set of industrial drills from a company several weeks ago. You have heard nothing from them since and now need the drills urgently. Write a fax to the company. Include the following points:

- 77.** Refer to order
- 78.** Stress need for drills
- 79.** Say what you will do if drills not sent soon

(Fax 2)

For examiner's use

Date: _____ Pages: 1

From: _____ To: _____

Attn: _____

S
Y
M
B
O
L

P
O
I
N
T
S

S
Y
M
B
O
L

P
O
I
N
T
S

S
Y
M
B
O
L

P
O
I
N
T
S

S
Y
M
B
O
L

P
O
I
N
T
S

Fax 1:

Fax 2:

GP GI

1st Correction

GP GI

Signature

GP GI

2nd Correction

GP GI

Do not mark any score here !

Signature

09 00000 4

| | | | | | | | | | | |
|--------------------------|--------------------------|--------------------------|--------------------------|--------------------------|--------------------------|--------------------------|--------------------------|--------------------------|--------------------------|--------------------------|
| <input type="checkbox"/> | <input type="checkbox"/> | <input type="checkbox"/> | <input type="checkbox"/> | <input type="checkbox"/> | <input type="checkbox"/> | <input type="checkbox"/> | <input type="checkbox"/> | <input type="checkbox"/> | <input type="checkbox"/> | <input type="checkbox"/> |
| <input type="checkbox"/> | <input type="checkbox"/> | <input type="checkbox"/> | <input type="checkbox"/> | <input type="checkbox"/> | <input type="checkbox"/> | <input type="checkbox"/> | <input type="checkbox"/> | <input type="checkbox"/> | <input type="checkbox"/> | <input type="checkbox"/> |
| | 1 | 2 | 1 | 2 | 1 | 2 | 1 | 2 | 1 | 2 |
| | 4 | 8 | 4 | 8 | 4 | 8 | 4 | 8 | 4 | 8 |

| | | | | | | | | | | |
|--------------------------|--------------------------|--------------------------|--------------------------|--------------------------|--------------------------|--------------------------|--------------------------|--------------------------|--------------------------|--------------------------|
| <input type="checkbox"/> | <input type="checkbox"/> | <input type="checkbox"/> | <input type="checkbox"/> | <input type="checkbox"/> | <input type="checkbox"/> | <input type="checkbox"/> | <input type="checkbox"/> | <input type="checkbox"/> | <input type="checkbox"/> | <input type="checkbox"/> |
| <input type="checkbox"/> | <input type="checkbox"/> | <input type="checkbox"/> | <input type="checkbox"/> | <input type="checkbox"/> | <input type="checkbox"/> | <input type="checkbox"/> | <input type="checkbox"/> | <input type="checkbox"/> | <input type="checkbox"/> | <input type="checkbox"/> |

Fax 1: Guiding Points (GP) 3 2 1 0 T

General Impression (GI) 2 1 0

Fax 2: Guiding Points (GP) 3 2 1 0 T

General Impression (GI) 2 1 0

... Information concerning the Answer Sheet S3 ...

Only answers marked on the Answer Sheet S3 can be scored.
Always use a pencil on the answer sheet.

Each item has only one correct answer.
For example, if you think that **c** is the correct answer,
mark your answer on the answer sheet
in the following way:

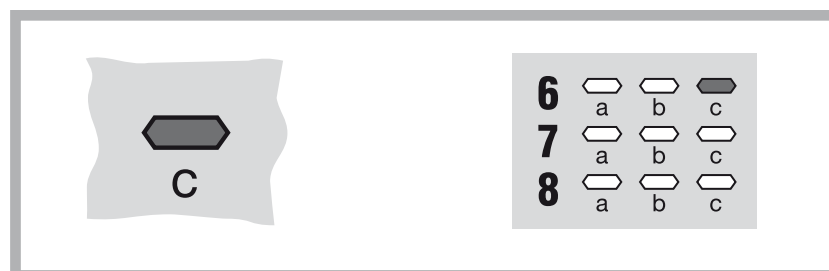

● Important Information:

This is the start of the Oral Examination.

If you wish to work through the mock examination as if it were a real examination, you need the help of a teacher to organise the test in the same way as a real examination is conducted. In this case, please do not read further than this page. You should not read any of the test items and you should not look at the information for teachers. Wait for the information and instructions your teacher gives you.

It is not possible for you to practise the oral examination by yourself.

If you simply wish to have a general overview all you need to do is to read the information in this booklet carefully. You will be able to familiarise yourself with the tasks and procedures as well as the assessment criteria used in the oral examination.

Each oral examination takes place with one candidate and two examiners. One of the examiners will do most of the talking.

It will have a positive effect on your marks if you speak as naturally as possible during the examination.

The oral examination consists of the following sub-tests

1. Social and General English
2. Business and Technical Situations
3. Technical Description

The time for the oral examination is 15 to 20 minutes. All three sub-tests are dealt with in this time.

1. Social and General English

In this sub-test you talk to the examiners about yourself. You are expected to talk freely and include information about work, study, home and interests. The examiners may ask you questions. You will be marked on how freely you speak and the language you use.

2. Business and Technical Situations

In this sub-test you respond to 5 business and social situations which the examiner will read to you. You are not allowed to take notes. You may ask the examiner to repeat each situation once.

3. Technical Description

In this sub-test you talk about an object, diagram or process from your working environment. You should be prepared for this and bring the material you need (object, drawings etc) with you. You may make notes and bring these with you but should not read from these during the examination. The examiners can ask you questions about the material.



Points and Grades

A maximum total of 125 points can be awarded for both parts of the examination (written and oral). There is a total of 100 points for the written examination and a total of 25 points for the oral examination.

To pass the whole examination, you must get at least 60% of the maximum total number of points in both the written and in the oral examination. This corresponds to a total of 60 points for the written examination and 15 points for the oral examination.

If you pass both parts of the examination, then the number of points awarded for the written examination is added to the number of points awarded for the oral examination to get the total. The grade is then awarded according to the following table.

| | | | |
|--------|---|---------------|--------------|
| 75.00 | – | 87.25 points | Pass |
| 87.50 | – | 99.75 points | Satisfactory |
| 100.00 | – | 112.25 points | Good |
| 112.50 | – | 125.00 points | Very Good |

If you fail or do not take one of the two parts of the examination you can retake that part of the examination during the calendar year in which you take the examination the first time or the following calendar year and have the points added together to get your final grade. The entire examination can be retaken as many times as you wish, e.g. if you fail or in order to get a better grade. It is, however, always the result of the final re-take which is valid.

Information for Teachers

This mock examination has been developed as preparation material for the telc English B2 Technical examination. It enables learners to check, with the help of their teacher whether they have reached the necessary level of language competence to pass the examination. All the information that teachers and learners need is given in this publication. Learners can become fully familiar with the examination format so that they know exactly what to do in the real examination situation. The mock examination can be used to simulate a real examination situation.

Examination Procedure

If you wish to simulate a real examination closely you should read the Instructions for the Written and Oral Examinations (available from telc GmbH). In order to be able to act as examiners for a telc Oral Examination teachers must attend an examiner training session and obtain an examiner's licence.

Written Examination

In a real examination

- candidates must enter their answers in a particular way so that these can be read automatically.
- candidates must write their names and personal details in block capitals so that these appear correctly on their certificates.
- under no circumstances is other material allowed apart from the examination booklets (dictionaries, grammar books, personal notes etc.).
- candidates must be informed that all attempts to cheat will lead to their exclusion from the examination and make the results invalid.
- the times for the different parts of the examination must be strictly kept to.
- all material (examination documents as well as personal notes) must be handed in after it has been used.
- the CD with the material for Listening Comprehension may not be stopped during the examination. All pauses are in the recording.

| | Material | Time in minutes |
|--|-------------------------------------|-----------------|
| Formalities | Examination Regulations | approx. 30 |
| Part 1 Specifications and Operations Technical Texts Language Elements | Examination Booklet Answer Sheet | 75 |
| BREAK | | 20 |
| Part 2 Listening Comprehension | Examination Booklet Answer Sheet | approx. 60 |
| Writing | Examination Booklet Answer Sheet | 25 |
| | | |



Oral Examination

In a real examination

- two examiners are necessary. Both examiners mark both candidates during the examination and compare marks after the candidates have left the room.
- candidates' names and marks must be recorded clearly on the score sheets.
- candidates are not allowed to communicate with each other during the preparation time. This will be regarded as cheating and will lead to their exclusion from the examination and make the results invalid.
- no other material may be used to answer the questions than that explicitly allowed.
- the times for the different parts of the oral examination and the total time must be kept to.
- candidates must hand in all material (task sheets as well as personal notes) after each examination.
- examiners may not give candidates information about their performance or their marks.

During the examination

- examiners should not confer with each other unless this is really necessary.
- candidates should talk as freely as possible.
- candidates should try to solve problems of communication or language themselves.
- examiners should only help if and when really necessary.
- examiners should keep to the time schedule and move from one part to the other smoothly.

After the examination examiners compare marks and transfer these to the answer sheet in the appropriate way.

Examination Schedule

| | Material | Time in minutes |
|---|-------------------------------|-----------------|
| Preparation (if necessary) | Candidates' Task Sheets | 20 |
| Part 1 Social and general English | Examination booklet | 3-5 |
| Part 2 Business and Social Situations | Examination booklet | 5 |
| Part 3 Technical Description | Examination booklet | 5-7 |
| Examiners' Discussion | Score Sheets Answer Sheets | 4-5 |

Introduce yourself and the second examiner and check the candidate's name.

Ask a few brief questions to put the candidate at ease and then continue.

Examples might be:

Have you been waiting a long time?

Did you have to come a long way today?

Then continue as follows:

Now could you tell us something about yourself?

80. The following section is marked!

The candidate is expected to talk freely for three to five minutes. The examiners may prompt with questions such as:

Where do you live?

Do you work full-time?

Do you use English often?

What are your interests or hobbies?

What sort of training have you had?

Do you travel a lot?

What are your working/study hours?

Now we would like to ask you what you would say in certain business and social situations. If there is something you don't understand we can repeat the question once.

Version 1

81. You are going to show a group of foreign technicians around your company. Introduce yourself and say something about the tour.
82. A representative from a company manufacturing photocopiers asks if your company would be interested in installing new photocopiers. Say you are not interested and explain why.
83. At an engineering exhibition you want more information about a particular product. Ask for this information and say why you are interested in the product.
84. A visitor comes to your office and asks to speak to your boss. Your boss is away on a business trip at the moment. Explain the situation and offer to help.
85. You are taking some visitors on a tour of your company. One of them asks if he may smoke. Tell him this is not possible and explain why.

Version 2

81. You are not very happy with the photocopying machines used in your company. Tell the supplier this and explain why.
82. Your assistant has not completed a piece of work on time. Say you are not very happy about this and tell him what you want him to do.
83. You are on a business trip to an English company. You are offered a cup of tea. Refuse and say why you don't want one.
84. You want to invite a foreign visitor to your company out to dinner. Tell him this and ask him what sort of food he prefers.
85. You are visiting a company for the first time. Introduce yourself at the reception desk and ask for directions to the Sales Department.

In this part of the examination the candidate will present a component, diagram or drawing s/he has brought to the examination. The following questions are suggestions for the examiners. The actual questions will depend on the candidate's presentation.

Can you describe the parts (of the diagram) individually ?

Can you explain (in more detail) how the system works?

What (else) could this be used for?

Can you suggest any improvements or modifications?

Is this the latest design or are there any further developments?

How long has this design been in use?

What (other) materials are used for the manufacture of this product?

What advantages does this product have over others?

Do you think this design will last a long time or can you foresee possible changes?

If the candidate has not brought any material to the examination, the diagram and text provided here can be used. In this case the candidate is given 15 minutes to prepare for the sub-test Technical Description. Candidates should be encouraged to bring their own material to the examination as in general they will score better in this part of the oral examination if they are talking about an object or process which is familiar to them. The following questions may be asked by the examiners:

What is the installation used for?

Could you describe the air flow through the individual components?

What is the purpose of the heat exchanger?

What is the purpose of the compressor?

What is the starter used for?

Why are starter, generator, compressor and turbine all mounted on the same shaft?

How is the fuel ignited?

Can you suggest modifications?

How fast do you think the turbine and compressor rotate?

M5-Eng(B2)T/Mock1 (For the participant)

Oral Examination

Please return to the examiner after use!

Gas Turbines

Gas turbines are driven by the combustion gases from liquid fuels. They resemble steam turbines in that a flowing medium – i.e. the combustion gases – produces a rotary motion as a result of driving a rotor. The operation of a gas turbine is shown schematically in Fig. 1: the compressor draws in fresh air and compresses it to a pressure of 50 – 70lb/in.²; the compressed air passes through a heat exchanger where it is preheated by the very hot exhaust gases; now the preheated air is admitted into the combustion chamber. In this chamber liquid fuel is burned, thereby producing gases with a temperature of about 650 degrees Celsius. These combustion gases flow at high velocity into the turbine and drive it.

The turbine itself, the compressor, and the electric generator are all mounted on one shaft. The turbine cannot transmit its entire power to the generator because a substantial part is needed for driving the compressor. The turbine is started with an electric motor which first has to set the compressor in motion in order to produce the compressed air necessary to form the combustion gases. Fig. 2 shows the main features of the gas turbine.

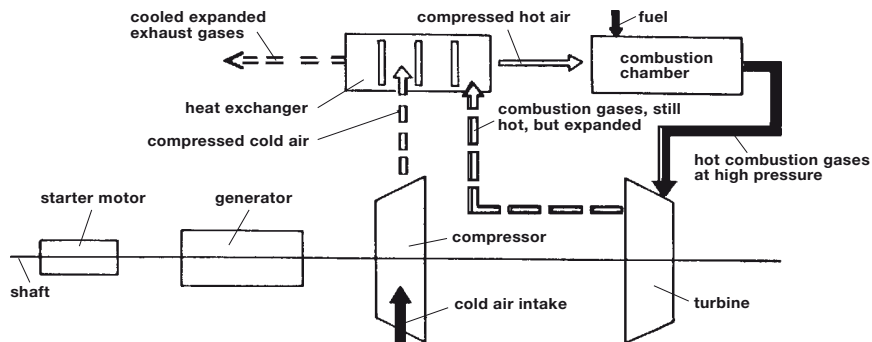

Fig. 1 GAS TURBINE (schematic)

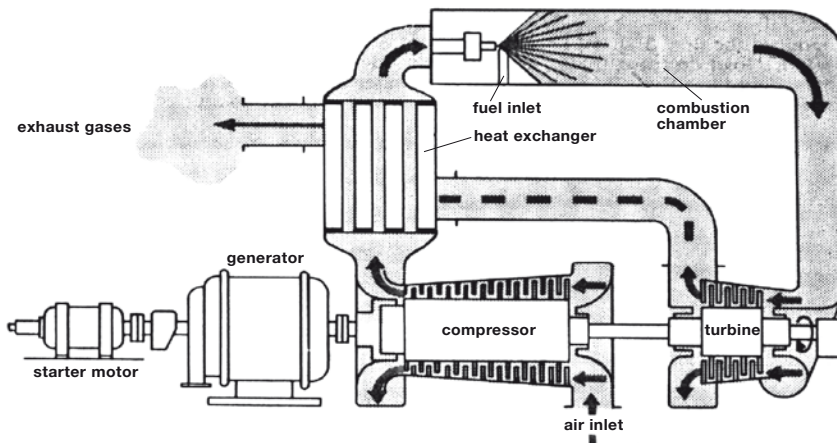

Fig. 2 GAS TURBINE



No part of this examination may be copied or stored under any circumstances. All violations will be prosecuted!
Dieses Dokument darf unter keinen Umständen kopiert oder aufbewahrt werden. Jeder Verstoß wird gerichtlich verfolgt!



Marking, Points and Grades

For the sub-tests **Specifications and Operations, Technical Texts, Language Elements, and Listening Comprehension** compare the learner's answers with the answer key. Award points as follows:

| | | |
|-------------------------------|---------------|-----------------|
| Specifications and Operations | Items 1 – 6 | 1 point each |
| | Items 7 – 8 | 2 points each |
| Technical Texts | Items 9 – 23 | 2 points each |
| Language Elements | Items 24 – 33 | 1 point each |
| Listening Comprehension | Items 34 – 43 | 1 point each |
| | Items 44 – 58 | 1 point each |
| | Items 59 – 63 | 2 points each |
| | Items 64 – 73 | 0.5 points each |

For the sub-test **Writing Faxes**, award points according to the marking criteria. For the **Oral Examination**, award points according to the marking criteria. Add together the points for the written examination and the oral examination separately. To pass the whole examination, a candidate must get at least 60% of the maximum total number of points in both the written and in the oral examination. This corresponds to a total of 60 points for the written examination and 15 points for the oral examination.

If the candidate has more than this minimum number of points in each part of the examination, then the number of points awarded for the written examination is added to the number of points awarded for the oral examination to get the final total.

In the real examination, if a candidate fails or does not take one of the two parts of the examination (written or oral) he/she can retake that part of the examination during the calendar year in which the examination is taken the first time or the following calendar year and have the points added together to get the final grade. The entire examination can be retaken as many times as the candidate wishes, e.g. to pass or to get a better grade. It is, however, always the result of the final re-take which is valid.

For the details on overall grading, see the inside back cover.



Marking Criteria **Writing Faxes**

A total of 10 points, 5 for each fax, can be awarded according to the following marking criteria:

For each guiding point which is covered in fully comprehensible English and is appropriate to the task set, one point will be awarded, making a total of three possible points. Language errors will only be taken into consideration if they lead to a breakdown in communication. If the examiner believes that the central element in an item may not be understood by the recipient, 0 points will be awarded for that item.

Up to two points can be awarded for each fax for the general impression given by the handling of the fax as a whole. 2, 1 or 0 points can be awarded for this.

Guiding Points 74 -79

All parts of the guiding points must be dealt with in order to gain 1 point. Only the information required in the guiding points should be marked. Any other information in the faxes is to be considered when awarding points for general impression.

0 points = meaningless, incomprehensible or irrelevant response; wrong information; no response at all.

1 point = correct and appropriate, covering all parts of the guiding point.

Language errors should not be taken into account here.

General Impression

0, 1 or 2 points can be awarded for general impression for each fax taken individually.

0 points = The entire fax is incomprehensible and/or
0 points have been awarded for the guiding points.
The fax does not correspond to the task set.

1 point = Fair linking and only occasionally inappropriate style. Some language errors but none impairing comprehension or communication.
(If the language errors are so numerous and severe that comprehension is impaired, then 0 points should be given.)

2 points = Good linking and largely appropriate style. Few language errors but none of these impairing comprehension and communication.

Marking Instructions Oral Examination

1: Social and General English

A, B, C or D will be awarded for this sub-test according to the following criteria:

| | |
|----------|------------|
| A | = 5 points |
| B | = 3 points |
| C | = 1 point |
| D | = 0 points |

- A:** The candidate speaks freely about him/herself and his/her work. The language is largely free of mistakes. Examiner prompts are kept to a minimum and are not necessary to keep the conversation going but rather to elicit further information on particular matters.
- B:** The candidate speaks freely about him/herself and his/her work. The language contains several mistakes but these do not impair communication. Examiner prompts are kept to a minimum and are not necessary to keep the conversation going but rather to elicit further information on particular matters.
- C:** The candidate speaks freely about him/herself and his/her work but the language contains several mistakes making checking questions necessary,
or
 the candidate is not in a position to speak freely and examiner prompts are necessary to keep the conversation going.
- D:** The candidate is not able to participate in this sub-test, i.e. does not speak at all,
or
 what the candidate says has no relevance to him/herself or his/her work,
or
 what the candidate says is incomprehensible.

2: Business and Technical Situations

A, B, C or D will be awarded per item according to the following criteria:

| | |
|----------|------------|
| A | = 4 points |
| B | = 3 points |
| C | = 1 point |
| D | = 0 points |

- A:** The response corresponds to the task set. It includes enough detail and is largely free of mistakes.
- B:** The response corresponds to the task set. It includes enough detail but contains a number of mistakes,
or
 within the context of natural communication it is very short, but contains no mistakes.
- C:** The response corresponds to the task set, but it is too short within the context of natural communication and contains a number of mistakes,
or
 the response is not entirely clear or appropriate in relation to the task set so that in a real-life situation a checking question would be necessary.
 This mark is also awarded if only one part of the situation is given as a response.
- D:** The response does not correspond to the task set,
and/or
 the response is incomprehensible.



Test 3: Technical Description

| | |
|----------|-------------|
| A | = 20 points |
| B | = 16 points |
| C | = 8 points |
| D | = 0 points |

A, B, C or D will be awarded according to the following criteria:

- A:** The performance is clear and fluent with very little hesitation requiring hardly any prompts by the examiner. The language is largely free of mistakes.
- B:** The performance is clear and fluent with little hesitation but contains a number of mistakes.
or
the performance is largely free of mistakes but the description is in itself not sufficiently clear and/or fluent so that the examiner has to use a number of prompts.
- C:** The description is unclear and lacks fluency and also contains a number of language mistakes, so that the examiner has to make frequent use of prompts and checking questions.
- D:** Despite the use of prompts and checking questions by the examiner the description is unclear and inappropriate.

Pronunciation and Intonation

| | |
|----------|------------|
| A | = 5 points |
| B | = 3 points |
| C | = 2 points |
| D | = 0 points |

A, B, C or D will be awarded for pronunciation and intonation for the whole of the oral examination, according to the following criteria:

- A:** Pronunciation and intonation show little divergence from accepted norms.
- B:** Pronunciation and intonation differ from accepted norms, but this does not impede understanding.
- C:** Pronunciation and intonation differ considerably from accepted norms, causing difficulty in understanding.
- D:** Pronunciation and intonation differ so greatly from accepted norms that comprehension is very difficult or impossible.

ANSWER KEY

Eng (B2) T Answer Key

- | | | | |
|-----|---|-----|-------------------|
| 1. | d | 34. | Valve plug |
| 2. | b | 35. | No |
| 3. | c | 36. | Yes |
| 4. | b | 37. | Reinforced rubber |
| 5. | b | 38. | No |
| 6. | c | 39. | No |
| 7. | + | 40. | Plugs |
| 8. | - | 41. | Yes |
| 9. | c | 42. | Counter weights |
| 10. | b | 43. | Yes |
| 11. | b | 44. | - |
| 12. | b | 45. | - |
| 13. | c | 46. | + |
| 14. | a | 47. | + |
| 15. | b | 48. | - |
| 16. | b | 49. | + |
| 17. | c | 50. | - |
| 18. | a | 51. | - |
| 19. | c | 52. | + |
| 20. | a | 53. | - |
| 21. | a | 54. | + |
| 22. | a | 55. | + |
| 23. | c | 56. | + |
| 24. | d | 57. | - |
| 25. | d | 58. | + |
| 26. | a | 59. | b |
| 27. | d | 60. | b |
| 28. | a | 61. | b |
| 29. | a | 62. | c |
| 30. | b | 63. | c |
| 31. | b | 64. | Muthswamy |
| 32. | d | 65. | 6.492 |
| 33. | b | 66. | 8-10 days |
| | | 67. | 215 by 312 |
| | | 68. | £75 - £82 |
| | | 69. | 065437560 |
| | | 70. | 8 ½ |
| | | 71. | 23,500 kg |
| | | 72. | £75.43 |
| | | 73. | FG 18654 A |

SPECIFICATIONS AND OPERATING PROCEDURES

Two Valves Used to Control Pressure

(fade in...).....Now, let's turn to diagram I. This diagram I shows an automatic valve used to control the water pressure downstream of it. As you probably know, such valves are used in industry and in town water supplies. In the diagram the pressure on the left is controlled. By opening and closing as needed, the valve keeps the downstream water pressure constant. It could be used to supply water at an even pressure to a street, so that the water pressure remains constant no matter how many houses in the street use the water.

Generally speaking, the valve operates like a water tap in a house. A cone-shaped metal part, called the valve plug, is pushed downwards into an angled metal hole, called the valve seat. When the two are in contact with each other no water can flow. Valve plug and valve seat can be seen in the centre of the diagram, there.

Now, if a tap downstream is opened the pressure downstream begins to fall. This lower pressure is present also in the chamber on the top of the valve – called the control chamber, because the chamber is connected to the main pipe downstream of the valve by a thin pipe, called the sensing tube. The domeshaped control chamber and the sensing tube are clearly seen in the diagram.

The control chamber is sealed across its greatest diameter by a thin disc of reinforced rubber, designed to have a very long operating life. The movement of the rubber seal is opposed by a spring – called the control spring – which fits over the plug shaft and is held compressed between the pipe section of the valve and the rubber seal.

A valve such as this one is not adjustable. To change the operating pressure a new rubber seal and control spring must be installed. However, it will operate for some years without maintenance.

Now let's turn to diagram II, which shows a similar valve to I, but adapted for a different purpose.

On the extreme right of this diagram you will see a water tank. This tank is filled through a pipe, drawn schematically with broken lines at the bottom of the diagram. Whether or not the tank is filled depends on the movements of a system of rods, levers and a level sensor which I'll explain in some detail now.

The ball shaped element situated in the float chamber next to the water tank is called the float. As its name suggests, the float floats on the surface of the water. Now, let us suppose the water level in the water tank falls. As it falls, the water level in the float chamber also falls and, consequently, so does the float. As the float moves down it will transmit its downward movement through a system of levers all the way down to the valve, where the two conical shaped plugs open the valve. You can see the plugs towards the bottom of the diagram in the centre of the valve.

A section of the rod, seen in the centre of the drawing, is made adjustable. This part serves to lengthen or shorten the rod, which connects the upper with the lower lever. Lengthening or shortening the rod will affect the opening and closing point of the valve.

There are two counterweights, mounted on the left hand sides of each of the two levers which serve to adjust the valve. Moving them horizontally along the levers will again alter the opening and closing point of the valve. The arrangement includes a non-return-valve located in the feed pipe at the bottom of the diagram. It's a safety device which, as you can see, will close if the water pressure in the feed pipe falls and it thus prevents the tank emptying if the water supply fails .

DISCUSSIONS AND LECTURES

Danger – Risky Kinobis

Interviewer (I): Tests done recently in the USA and here in Britain as well as reports from owners of Kinobi cars have shown that Kinobi BKs can roll over at speeds as low as 20 miles per hour. I am going to talk to Marion Fielding from the Car-Owners' Association about the tests done and the accidents that have happened as a result of this danger in Kinobi cars. Marion, why did you, the Car-Owners' Association, decide to do tests on these cars?

Marion Fielding (MF): Well, last year we heard that the Car-Owners' Federation in the United States had found that the Kinobi Karo was liable to roll over when being put through their accident avoidance test. We had only had a few reports of accidents involving this type of car but we decided to find out more about these accidents by doing our own tests.

I: And what have your tests found?

MF: Our own tests were done on only two different Kinobi BKs rather than on all the different models. These tests support the US results. These cars are liable to roll over, instead of sliding like most other cars, when going round a corner sharply. We think that this is unacceptable to Kinobi drivers, their passengers, and other road users in general.

I: How were the tests done?

MF: We put the Kinobis at 20 miles per hour through a test which includes a very tight bend. Our driver had to stop this test in the middle because he was sure the car would roll over.

I: Have you done this test on many other types of car?

MF: Oh, yes. We've been doing this test on cars for 25 years – normally at twice the speed - and have never before found a car so liable to roll over.

I: Does Kinobi know about this danger?

MF: The company knows that the cars are far less stable than other cars. Their handbook even advises drivers to avoid sharp turns. It says that failure to operate the car correctly may result in loss of control or the car

rolling over. But we feel that even a very careful driver might find himself in situations where he cannot avoid a sharp turn. No car should roll over if going at a low speed.

I: Have there been many accidents because of this?

MF: We've now heard of 24 cases of Kinobis rolling over at quite low speeds. These have resulted in 2 deaths and 23 people hurt. There have been 95 accidents of this kind reported in the US.

I: Is anything being done about it?

MF: We have told the Ministry of Transport about what we have found as well as Kinobi. We've asked Kinobi to stop selling these cars and to warn all owners. But nothing has happened. We feel very strongly that something must be done before more people are killed or hurt. A number of accidents have happened although drivers were doing nothing dangerous at all and were not even driving fast. Since doing the tests, we have heard of accidents in other parts of the world as well as accidents which happened when using reverse gear, braking suddenly and driving in and out of narrow entrances. We do not have details of these accidents but we would warn Kinobi owners to think very carefully about using their cars and especially about letting other drivers use them. Also we would like to hear from anyone who has had an accident with one of these cars or any other Kinobi model.

I: Thank you very much, Marion, for this information.

Cooling down process heat.

Heat, or waste heat, is an almost natural by-product of many industrial processes. This is particularly true for the generation of electrical power in thermal power stations. Thermal power stations are those that generate electricity by means of burning fossil fuels, but also in nuclear power stations. In such power stations the laws of physics limit the reduction of waste heat beyond a certain point. If this heat cannot be put to any sensible use it must be cooled down. Several approaches to cooling down this process heat exist, and I will explain two of them now.

Figure A shows the once-through cooling system. A once-through cooling system uses water drawn either from a lake or a river to supply cooling water to the heat exchanger. The heated water is then returned to the body of water. As a result of all the heat being discharged into rivers or lakes with such a system, the term "thermal pollution" has assumed significance. Laws now severely restrict the use of once-through cooling so that often it's not even available as an option.

In such cases closed-cycle cooling systems present an alternative. The next figure, Figure B, shows a closed-cycle cooling system. Here the cooling water is continuously recirculated through the power plant by means of large pumps. A cooling tower is used to remove the heat added to the circulating water. Now, water drawn from a natural source, again this could either be a lake or a river, would be used only to make up for losses. This isn't very much and the job is done by a small pump seen here as pump Y. Figure B shows a mechanical-draft cooling tower in which a large diameter fan driven by an electric motor forces air through the circulating water. There are also natural-draft design towers which do not need electricity to drive the fans. They are thus more energy efficient but the towers are much taller and they are therefore often not wanted for environmental reasons.

INSTRUCTIONS AND DESCRIPTIONS

59. New Developments in the Car Industry

Battery powered cars provide clean and noiseless alternatives to fuel powered vehicles for travel in cities. Asea Brown Boveri developed an efficient drive system featuring modern power electronics and a high-energy rechargeable sodium-sulphur battery as the prime mover. The energy-to-weight ratio of this battery is four times that obtained by lead batteries. The new battery, which operates at 300 degrees Celsius has no secondary reactions or gaseous emissions and its electrical efficiency is very high. Other electric vehicles require a dense network of charging stations. ABB has overcome this problem by developing an onboard battery charger mounted next to the motor which only needs to be connected to a household power socket. The new drive system will enable a typical car to be driven at 120 kilometres per hour over a range of 200 kilometres in town traffic.

60. Shop-floor Safety Instruction

When working with this lathe you must remember to clean it after each work period. Clean it with a medium width paint brush to remove all the metal chips. Never, I repeat, never use your hands as these metal chips can be very sharp. Also, don't use compressed air as flying particles might injure you or a nearby person. Finish by wiping down the machine with a soft cloth.

Keep the floor around the machine clear of chips and cutting fluid and keep oily cloths in a metal container that can be closed tightly, as they present a fire hazard. Most importantly, however, always wear appropriate clothing and goggles and avoid wearing greasy clothes - they catch fire easily. Now, let's come to the operation of the lathe(fade out)

61. Solar heating.

The simplest solar energy systems are those designed for domestic space and hot water heating. In such systems, an inclined, southerly facing collector is typically coupled with a heat storage tank. The hot water

collected in this tank heats up water for the hot water supply or for hot water heating. Diagram A shows a combination system that provides domestic hot water at 65 degrees Celsius and hot water for space heating at somewhat lower temperatures. Two pumps are needed, one to circulate water through the collector, and a second one to provide hot water for space heating. Neither of them run constantly but only when the sun shines - for the collector pump - and when hot water for space heating is needed for the other one.

Figure B shows a one-axis concentrator. It can be used if a simple flat-plate fixed collector does not provide high enough output temperatures, for example to produce steam for industrial purposes. The one-axis concentrator can be used for high efficiency and high temperatures at fairly low costs. The design shown in Figure B has a programmable drive to automatically follow the path of the sun.

62. High Tension Cables for Car Ignition Systems

In the past high tension cables for car ignition systems were constructed from a low resistance copper core enclosed in a rubber covering which gave the cable the necessary insulation. The rubber was then covered with a cotton band and the whole cable was coated with a kind of paint to protect it from wear and corrosion. In the new high tension cables the copper core has remained unchanged but the cotton and paint layers have been replaced with inorganic material. This is more efficient in protecting the rubber from heat, cold, oil, wear and corrosion.

63. Comparing energy costs.

Diagram I will serve to illustrate our brief comparison between hydrogen, natural gas and electricity as sources of energy. The columns show clearly that the end price for natural gas is much lower than the price for hydrogen gas and electricity. Not only are the production costs of natural gas lower but also the costs for transmission and distribution. The column for hydrogen energy shows interesting characteristics. While the production cost is higher than the one for electric power, the final selling price is lower due to relatively low transmission and distribution costs. It is however still more expensive than the price of natural gas energy. But this may change in the future, as obviously, there are only limited resources of natural gas so that in the future hydrogen energy may become a very competitive form of energy.

TAKING NOTES

64. What is your name, please?

My name is Muthswamy. That's M-U-T-H-S-W-A-M-Y

65. How many employees do you have exactly?

We now have 6492 employees.

66. When can you deliver the goods?

They will be sent to you in 8 to 10 days.

67. What size is the paper?

The paper is slightly larger than A4. It measures 215 millimetres by 312 millimetres.

68. What is the initial cost of each lens?

Each lens will initially cost 75 to 82 Pounds Sterling.

69. Can you give me your fax number?

My number is 06543 7650

70. What size are they?

We use American sizes, so that's eight and a half.

71. What is the weight of the consignment?

The consignment will have a total weight of 23,500 kilograms.

72. How much is the VAT on that order?

The VAT amounts to 75.43 Pounds Sterling.

73. Can you tell me the invoice number?

The number is FG 18654A

With telc
you can prove your
knowledge of foreign
languages.



You can show that you are ready for the Europe of the 21st century. telc demonstrates your

- ability to communicate in all everyday situations
- ability to write letters, faxes and e-mails
- ability to understand spoken and written texts in the foreign language, e.g. newspaper articles, advertisements, personal statements, radio and TV news broadcasts or interviews
- awareness of intercultural differences in the foreign language

Improve your career prospects by taking telc examinations. There are more than 3,000 examination centres throughout Europe.

If you would like to know more about telc contact us by fax or E-mail. We can tell you where your nearest centre is and when the next test dates are.

Fax: ++49 69 956246-62

E-mail: info@telc.net

Or simply visit our website (www.telc.net) where you will find all the information you need. We look forward to hearing from you.

Our system of vocational and general language

CERTIFICATES IN ENGLISH



Grading

To grade the results obtained, take the scores from the answer sheet S3, from the letter sheet (total score) and from the oral examination score sheet (M11), and enter them in the tables below.

Name _____

| Written Examination | Possible points | Points scored |
|---|-----------------|---------------|
| 1 Reading Comprehension Part A (1 – 8) | 6 (6x1) | |
| | 4 (2x2) | |
| Part B (9 – 23) | 30 (15x2) | |
| 2 Language Elements (24 – 33) | 10 (10x1) | |
| 3 Listening Comprehension Part A (34 – 43) | 10 (10x1) | |
| Part B (44 – 58) | 15 (15x1) | |
| Part C (59 – 63) | 10 (5x2) | |
| Part D (64 – 73) | 5 (10x0.5) | |
| 4 Writing Faxes Fax 1 (74 – 76) | 5 | |
| Fax 2 (77 – 79) | 5 | |
| Total | 100 | |

| Oral Examination | Possible points | Points scored |
|--|-----------------|---------------|
| 1 Social and General English (80) | 5 | |
| 2 Business and Technical Situations (81 – 85) | 20 (5x4) | |
| 3 Technical Description (T) | 20 | |
| Pronunciation and Intonation (P) | 5 | |
| Total | 50 | 50:2=25 |

| | Possible points | Points scored |
|---------------------|-----------------|---------------|
| Written Examination | 100 | |
| Oral Examination | 25 | |
| Overall Result | 125 | |

In order to pass the whole examination the candidate must achieve a total of 60 % of the possible total in **both** the Written and Oral Examination (i.e. **at least 15 points in the Oral Examination** and **at least 60 points in the Written Examination**).

Grades are awarded as follows:

| Overall result (points) | Grade |
|-------------------------|--------------|
| 75.00 – 87.25 | pass |
| 87.50 – 99.75 | satisfactory |
| 100.00 – 112.25 | good |
| 112.50 – 125.00 | very good |

A candidate may retake either the written and oral examination, if he or she does not pass one of these parts or does not take one of them.

Mock Examination 1

ENGLISH

TECHNICAL

The two main characteristic features of telc examinations are test papers based on language tasks formulated in a clear and understandable way and standardised marking criteria applied in an objective way. The comprehensively defined test specifications and uniform marking criteria ensure that these features apply to all examinations and are identical for all languages covered by the telc programme. This equally applies to the test format. The mock examination presented here enables teachers and learners to simulate the precise conditions under which the examinations take place, both from the perspective of organising the test as well as from the point of view of the test materials. In this way, it is possible to fully prepare candidates for the examination. The mock examination can also be used for practice purposes, for examiner training and for general information.

Order No. C09M-001B ISBN 978-3-933908-68-1